

LINEA

5940XSC100R05-28 RAL9002

EAN 4031582352702



Afbeelding kan verschillen van het oorspronkelijke product

PRESTATIES

Rolprestaties	● ● ● ● ●
Bewegingsgeluid	● ● ● ○ ○
Verloop	● ● ● ● ○
Corrosieweerstand	● ● ● ● ○

KERNKENMERKEN

Productnaam	Linea
Type	Zwenkwiel
Standaard	EN12530 - Apparaten zwenkwielen
Draagvermogen bij 3 km/u	120 kg
Elektrisch geleidend	✓
Roestvrij	✓
Statisch Draagvermogen	240 kg
Temperatuurbereik (minimaal)	-10 °C
Temperatuurbereik (maximaal)	40 °C
Totale hoogte	120 mm
Totale breedte	82 mm
Totaal gewicht	0,827 kg

WIEL

Wielkern materiaal	Polyamide, elektrisch geleidend
Materiaal loopvlak	Polyurethaan, gespoten, elektrisch geleidend
Lager	Precisiëkogellager, roestvrij
Afdekkapjes	Met afdekkapjes
Diameter	100 mm
Breedte Loopvlak	20 mm
Hardheid van het loopvlak (A)	92 Shore A

VORK

Materiaal	Polyamide
Vork Vorm	Dubbele vorkwiel
Zwenklager	Precisiëkogellagers
Kleur	Grijs wit (RAL9002)
Offset	32 mm
Zwenk radius	90 mm
Uitzwenking	180 mm
Diameter koepel	52 mm

BEVESTIGING

Type bevestiging	Vaste Stift, rond
Diameter Bout	28 mm
Lengte Bout	40 mm



Duitse
OntwerpersClub



Interzum
Award



IF
Design
Award

LINEA

5940XSC100R05-28 RAL9002

EAN 4031582352702



BETTER MOBILITY. BETTER LIFE.

TECHNISCHE TEKENINGEN

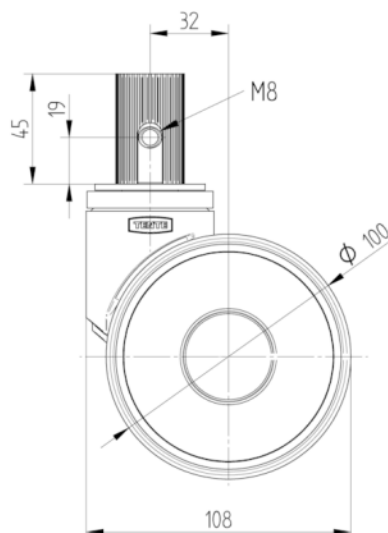
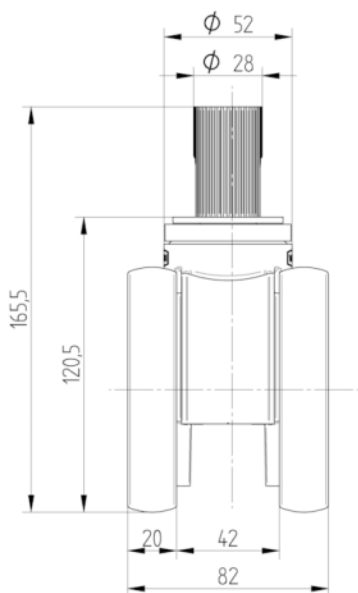

Duitse
OntwerpersClub



Interzum
Award



IF
Design
Award