

LINEA LIGHT

5925UAI065L51-10 KICK PEDAL

EAN 4031582403893



BETTER MOBILITY. BETTER LIFE.



Image may differ from the original product

PERFORMANCE

Roll performance	● ● ● ○ ○
Movement noise	● ● ● ○ ○
Attrition	● ● ● ○ ○
Corrosion resistance	● ● ● ● ○

CORE ATTRIBUTES

Product name	Linea light
Type	Swivel castor with wheel brake
Standard	EN12528 - Furniture Castors
Load capacity at 3 km/h	60 kg
Load capacity Static	120 kg
Temperature range (Minimum)	-10 °C
Temperature range (Maximum)	40 °C
Overall height	68 mm
Overall width	46 mm
Overall weight	0.114 kg

WHEEL

Body material	Polyamide
Tread material	Polyurethane, injected
Bearing	Plain bearing with spacer tube
Threadguards	Without threadguard
Diameter	65 mm
Tread width	13.9 mm
Hardness of tread (A)	87 Shore A

HOUSING

Material fork	Polyamide
Fork shape	Twin wheel housing
Swivel bearing	Stem, swiveling
Swivel radius	67 mm
Swivel interference	134 mm
Dome diameter	23 mm

FITTING

Fitting type	Blind hole for B10
Bolt hole diameter	10 mm



LINEA LIGHT

5925UAI065L51-10 KICK PEDAL

EAN 4031582403893



BETTER MOBILITY. BETTER LIFE.

TECHNICAL DRAWINGS

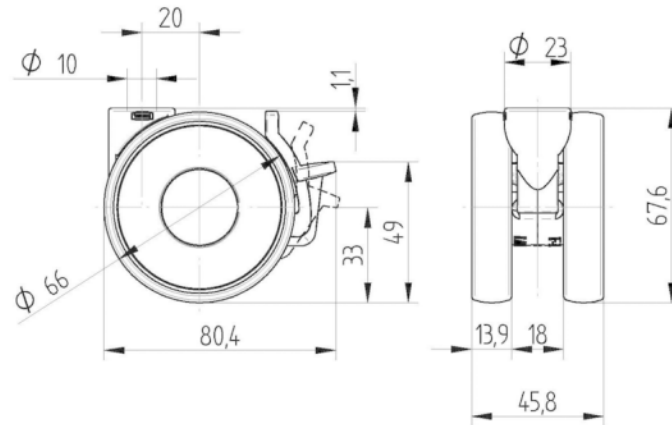

Deutscher
Designer
Club



Interzum
Award



IF
Design
Award