

LINEA LIGHT

5920XSP100L51-11 RAL7001

EAN 4031582370720



BETTER MOBILITY. BETTER LIFE.



Image may differ from the original product

PERFORMANCE

Roll performance ●●●○○

Movement noise ●●●○○

Attrition ●●●○○

Corrosion resistance ●●●●○

CORE ATTRIBUTES

Product name	Linea light
Type	Swivel castor
Standard	EN12528 - Furniture Castors
Load capacity at 1.8 mph	220.46 lb
Electric conductive	✓
Load capacity Static	440.92 lb
Temperature range (Minimum)	14 °F
Temperature range (Maximum)	104 °F
Overall height	3.94 in
Overall width	2.87 in

WHEEL

Body material	Polyamide, electric conductive
Tread material	Polyurethane, injected, electric-conductive
Bearing	Precision ball bearing
Threadguards	With threadguard
Diameter	3.94 in
Tread width	0.79 in

HOUSING

Material	Polyamide
Fork shape	Twin wheel housing
Swivel bearing	Stem, swiveling
Color	Silver gray (RAL7001)
Offset	1.26 in
Swivel radius	3.46 in
Swivel interference	6.93 in
Dome diameter	1.57 in

FITTING

Fitting type	Blind hole for B10 fitting
Bolt hole diameter	0.43 in



LINEA LIGHT

5920XSP100L51-11 RAL7001

EAN 4031582370720



BETTER MOBILITY. BETTER LIFE.

TECHNICAL DRAWINGS

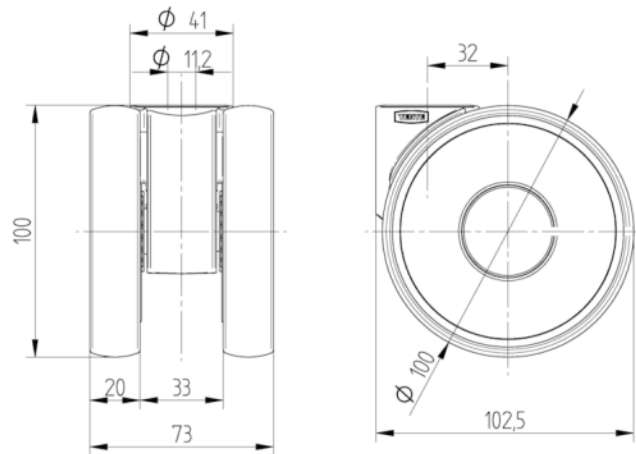

Deutscher
Designer
Club



Interzum
Award



IF
Design
Award