

LINEA

5940UAP150R05-22

EAN 4031582408942



BETTER MOBILITY. BETTER LIFE.



Image may differ from the original product

PERFORMANCE

Roll performance	● ● ● ● ●
Movement noise	● ● ● ● ○
Attrition	● ● ● ● ○
Corrosion resistance	● ● ● ● ○

CORE ATTRIBUTES

Product name	Linea
Type	Swivel castor
Standard	EN12530 - Devices Castors
Load capacity at 1.8 mph	286.6 lb
Load capacity Static	573.2 lb
Temperature range (Minimum)	-4 °F
Temperature range (Maximum)	140 °F
Overall height	6.69 in
Overall width	3.5 in
Overall weight	2.43 lb

WHEEL

Body material	Polyamide
Tread material	Polyurethane, injected
Bearing	Precision ball bearing
Threadguards	With threadguard
Diameter	5.91 in
Tread width	0.87 in
Hardness of tread (A)	92 Shore A

HOUSING

Material	Polyamide
Fork shape	Twin wheel housing
Swivel bearing	Precision ball bearing
Offset	2.05 in
Swivel radius	5.24 in
Swivel interference	8.58 in
Dome diameter	2.2 in

FITTING

Fitting type	Solid stem, round
Bolt diameter	0.87 in
Bolt length	1.57 in



LINEA

5940UAP150R05-22

EAN 4031582408942



BETTER MOBILITY. BETTER LIFE.

TECHNICAL DRAWINGS

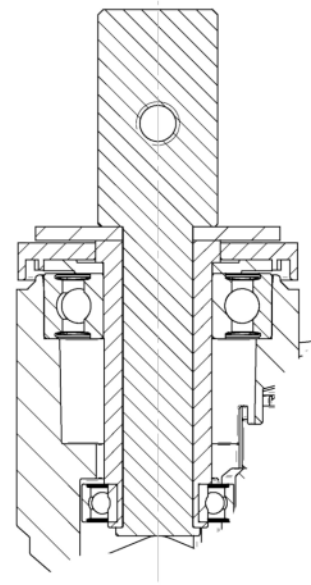
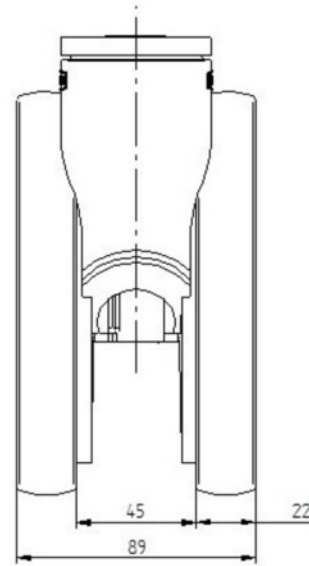
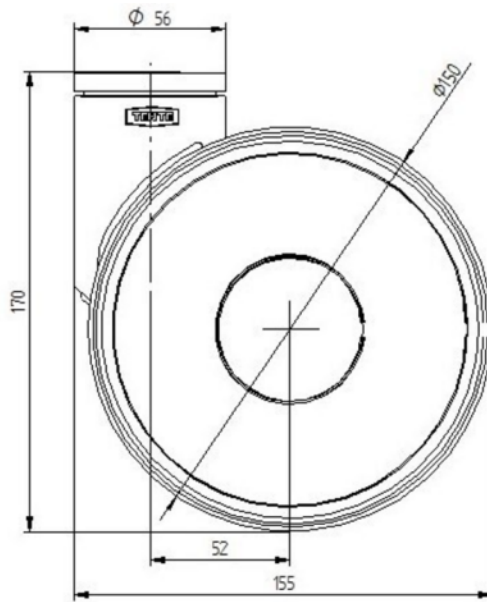

Deutscher
Designer
Club



Interzum
Award



IF
Design
Award