

LINEA E-LOCK

594EUSP150R36-32 N RAL9002

EAN 4031582489309



BETTER MOBILITY. BETTER LIFE.



Image may differ from the original product

PERFORMANCE

| | |
|----------------------|-------------|
| Roll Performance | ● ● ● ● ● ● |
| Movement Noise | ● ● ● ● ○ |
| Attrition | ● ● ● ● ● ○ |
| Corrosion Resistance | ● ● ● ● ○ ○ |

CORE ATTRIBUTES

| | |
|-----------------------------|--|
| Product Name | Linea E-Lock |
| Type | Swivel castor with electric locking system |
| Standard | EN12531 - Hospital Bed Castors |
| Load capacity at 3 km/h | 150 kg |
| Load capacity at 4 km/h | 150 kg |
| Electric Conductive | Yes |
| Stainless | Yes |
| Load capacity Static | 300 kg |
| Temperature range (Minimum) | -10 °C |
| Temperature range (Maximum) | 40 °C |
| Overall Height | 155 mm |
| Overall width | 71 mm |
| Overall weight | 1.52 kg |

HOUSING

| | |
|---------------------|------------------------|
| Housing Material | Polyamide |
| Fork shape | Twin wheel housing |
| Swivel Bearing | Precision ball bearing |
| Housing Color | Grey white (RAL9002) |
| Offset | 47.5 mm |
| Swivel radius | 127 mm |
| Swivel interference | 254 mm |
| Dome diameter | 45.5 mm |

WHEEL

| | |
|-----------------------|---|
| Body material | Polyamide |
| Tread Material Mix | Polyurethane, injected, electric-conductive |
| Bearing | Precision ball bearing |
| Wheel Color | Grey white (RAL9002) |
| Threadguards | With threadguard |
| Diameter | 150 mm |
| Tread width | 15 mm |
| Body width | 15 mm |
| Hardness of tread (A) | 92 Shore A |
| Hardness of tread (D) | 42 Shore D |

FITTING

| | |
|------------------------------|--|
| Fitting type | Stem with cam hole for profile bars, short version |
| Bolt diameter | 32 mm |
| Bolt length | 50 mm |
| Bolt thread position | 7 mm |
| Bolt mounting holes quantity | 2 |



Deutscher Designer Club



Interzum Award



IF Design Award

product design award

LINEA E-LOCK

594EUSP150R36-32 N RAL9002

EAN 4031582489309

Order number 00065310
Product Drawings



BETTER MOBILITY. BETTER LIFE.

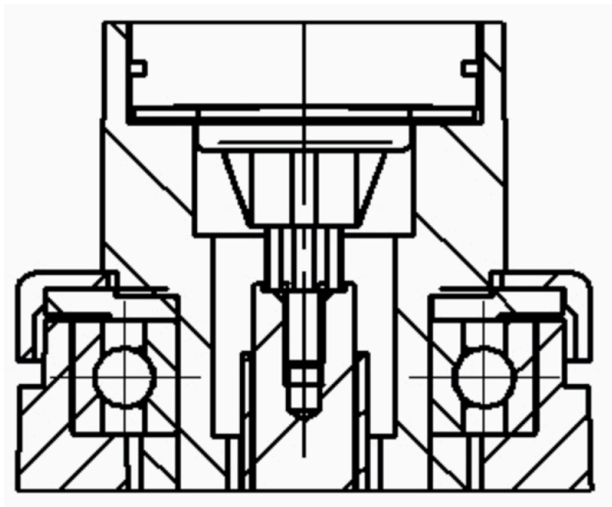
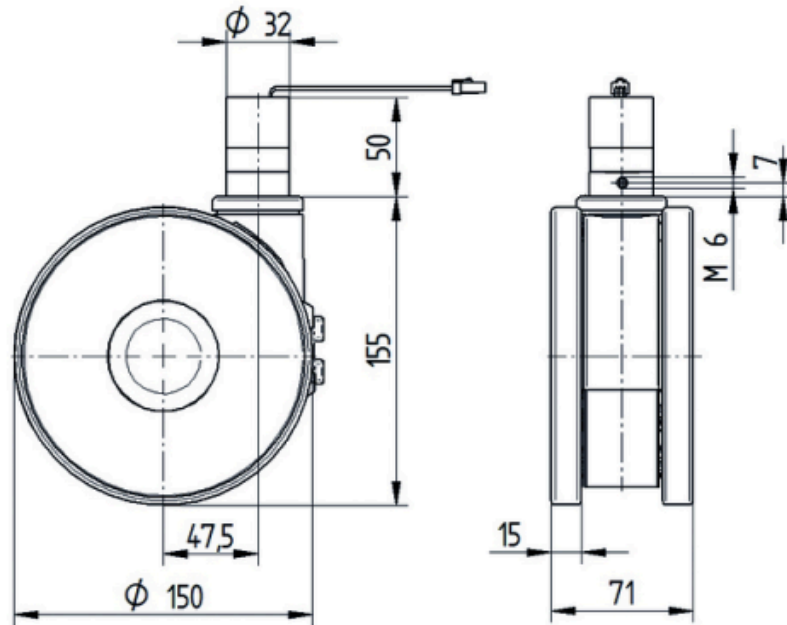

Deutscher
Designer
Club



Interzum
Award



product
design
award

IF Design
Award