

# NOVATECH

FTP 300x80-Ø30 HL92

EAN 4031582331097



BETTER MOBILITY. BETTER LIFE.



Image may differ from the original product

## WHEEL

Body material	Cast iron
Tread Material Mix	Polyurethane, casted
Bearing	Precision ball bearing
Wheel Color	Honey yellow (RAL1005)
Threadguards	With threadguard
Diameter	300 mm
Tread width	80 mm
Axle Hole Diameter	30 mm
Hub Length	92 mm
Body width	80 mm
Hardness of tread (A)	92 Shore A
Hardness of tread (D)	42 Shore D

## PERFORMANCE

Roll Performance	●●●●○
Movement Noise	●●●○○
Attrition	●●●●○
Corrosion Resistance	●●●○○

## CORE ATTRIBUTES

Product Name	Novatech
Type	Wheel
Standard	EN12533 - Heavy Duty Castors
Load capacity at 4 km/h	2400 kg
Load capacity at 6 km/h	2000 kg
Electric Conductive	No
Stainless	No
Load capacity Static	4000 kg
Temperature range (Minimum)	-10 °C
Temperature range (Maximum)	60 °C
Overall weight	14.86 kg

# NOVATECH

FTP 300x80-Ø30 HL92

EAN 4031582331097

Order number 00800996  
Product Drawings



BETTER MOBILITY. BETTER LIFE.

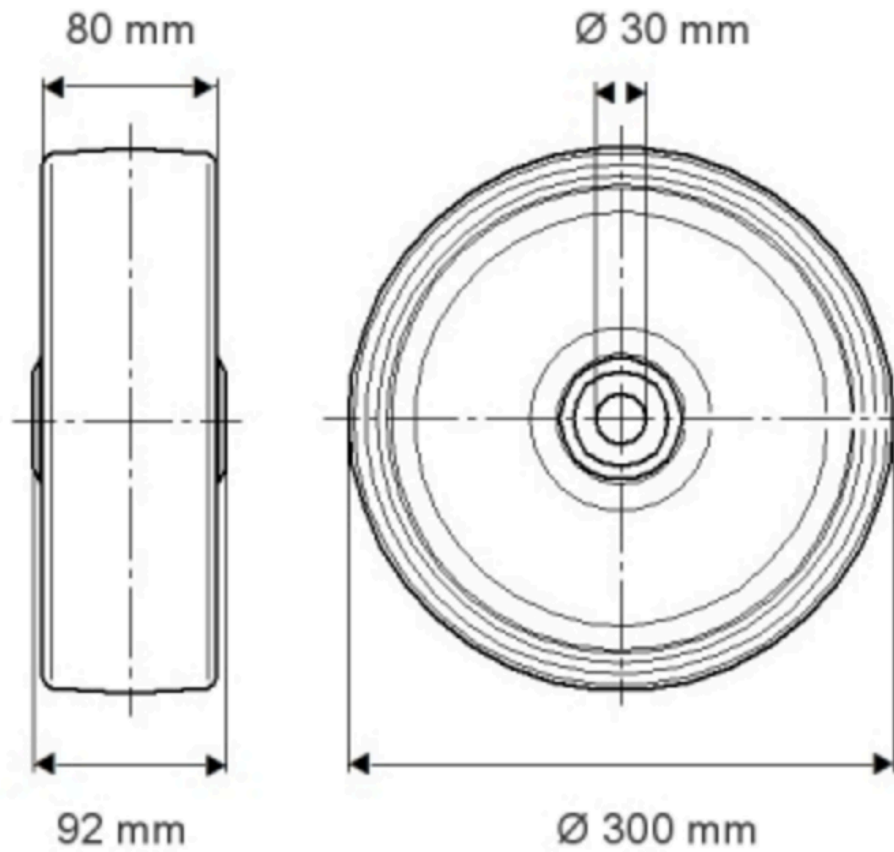

PRODUCT INFORMATION

# NOVATECH

FTP 300x80-030 H192

EAN 4031582381087

Order number 00800996

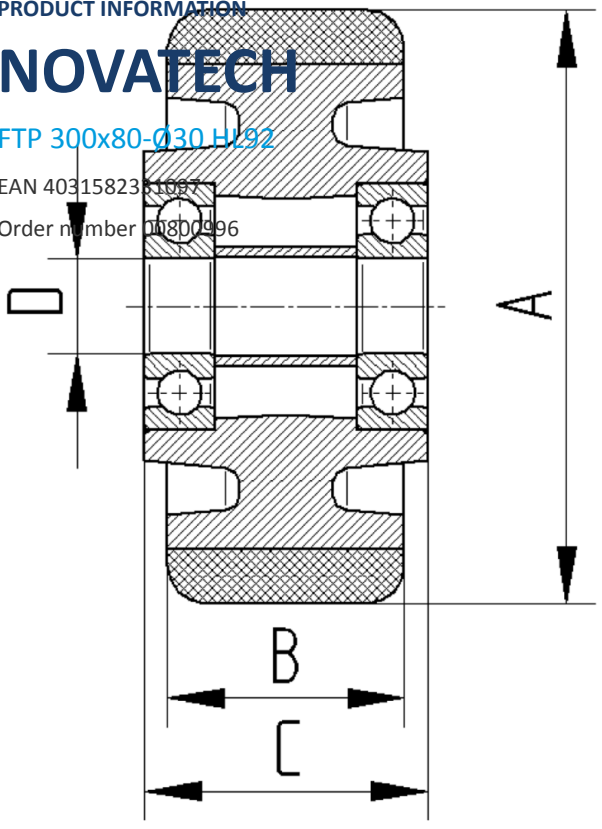

BETTER MOBILITY. BETTER LIFE.