

# LEVINA

5371XSP100P30-13

EAN 4031582359350



BETTER MOBILITY. BETTER LIFE.



Image may differ from the original product

## PERFORMANCE

|                      |       |
|----------------------|-------|
| Roll performance     | ●●●○○ |
| Movement noise       | ●●●●○ |
| Attrition            | ●●●●○ |
| Corrosion resistance | ●●●●○ |

## CORE ATTRIBUTES

|                             |                                     |
|-----------------------------|-------------------------------------|
| Product name                | Levina                              |
| Type                        | Swivel castor with directional lock |
| Standard                    | EN12530 - Devices Castors           |
| Load capacity at 3 km/h     | 100 kg                              |
| Electric conductive         | ✓                                   |
| Load capacity Static        | 200 kg                              |
| Temperature range (Minimum) | -10 °C                              |
| Temperature range (Maximum) | 40 °C                               |
| Overall height              | 137 mm                              |
| Overall weight              | 0.505 kg                            |

## WHEEL

|                       |   |
|-----------------------|---|
| Body material         | Polyamide, electric conductive              |
| Tread material        | Polyurethane, injected, electric-conductive |
| Bearing               | Precision ball bearing                      |
| Threadguards          | With threadguard                            |
| Diameter              | 100 mm                                      |
| Tread width           | 32 mm                                       |
| Hardness of tread (D) | 40 Shore D                                  |

## HOUSING

|                     |                |
|---------------------|----------------|
| Material fork       | Polyamide      |
| Fork shape          | Slim           |
| Swivel bearing      | Two ball races |
| Offset              | 36 mm          |
| Swivel radius       | 98 mm          |
| Swivel interference | 196 mm         |

## FITTING

|                    |           |
|--------------------|-----------|
| Fitting type       | Bolt hole |
| Bolt hole diameter | 13 mm     |



# LEVINA

5371XSP100P30-13

EAN 4031582359350



BETTER MOBILITY. BETTER LIFE.

## TECHNICAL DRAWINGS

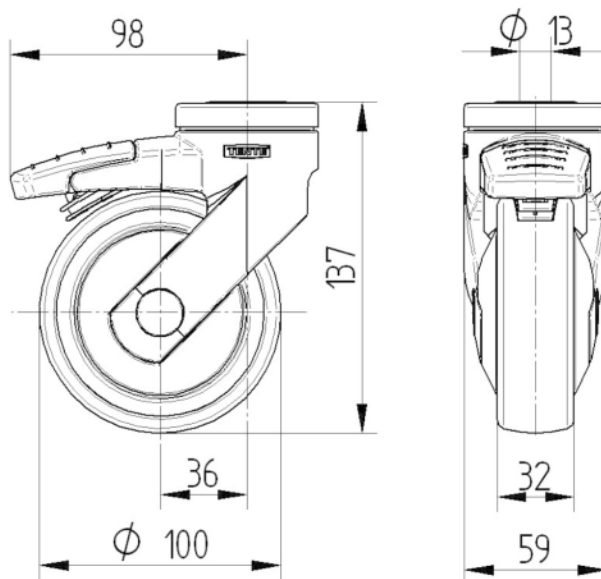

Universal  
Design  
Award



Deutscher  
Designer  
Club