

LINEA LIGHT

5925PJI075L51-10 RAL9002

EAN 4031582377491



BETTER MOBILITY. BETTER LIFE.



Image may differ from the original product

PERFORMANCE

Roll performance	● ● ● ● ●
Movement noise	● ● ● ● ●
Attrition	● ● ● ● ●
Corrosion resistance	● ● ● ● ●

CORE ATTRIBUTES

Product name	Linea light
Type	Swivel castor with wheel brake
Standard	EN12528 - Furniture Castors
Load capacity at 1.8 mph	132.28 lb
Load capacity Static	264.55 lb
Temperature range (Minimum)	-4 °F
Temperature range (Maximum)	140 °F
Overall height	2.97 in
Overall width	2.17 in
Overall weight	0.34 lb

WHEEL

Body material	Polypropylene
Tread material	Thermoplastic rubber
Bearing	Plain bearing with spacer tube
Threadguards	Without threadguard
Diameter	2.95 in
Tread width	0.59 in
Hardness of tread (A)	92 Shore A

HOUSING

Material	Polyamide
Fork shape	Twin wheel housing
Swivel bearing	Stem, swiveling
Color	Gray white (RAL9002)
Offset	0.91 in
Swivel radius	3.23 in
Swivel interference	6.46 in

FITTING

Fitting type	Blind hole for B10 fitting
Bolt hole diameter	0.39 in



Deutscher Designer Club



Interzum Award



IF Design Award

LINEA LIGHT

5925PJI075L51-10 RAL9002

EAN 4031582377491



BETTER MOBILITY. BETTER LIFE.

TECHNICAL DRAWINGS

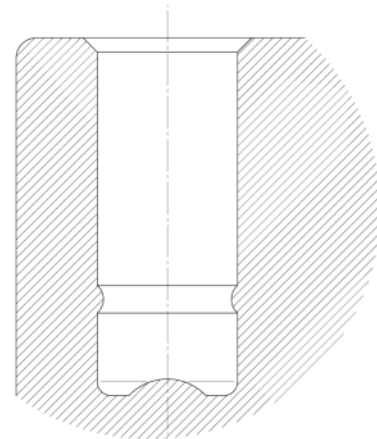
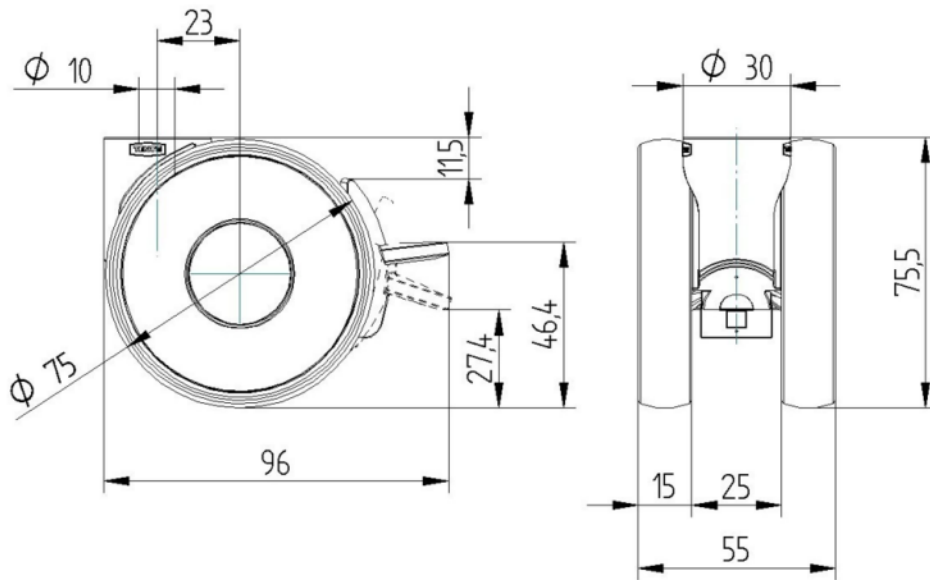

Deutscher
Designer
Club



Interzum
Award



IF
Design
Award