

INTEGRAL

2070PJP150R05-32

EAN 4031582348408



Image may differ from the original product

PERFORMANCE

Roll performance	● ● ● ○ ○
Movement noise	● ● ● ○ ○
Attrition	● ● ● ○ ○
Corrosion resistance	● ● ● ○ ○

CORE ATTRIBUTES

Product name	Integral
Type	Swivel castor
Standard	EN12530 - Devices Castors
Load capacity at 3 km/h	100 kg
Load capacity Static	200 kg
Temperature range (Minimum)	-20 °C
Temperature range (Maximum)	60 °C
Overall height	188 mm
Certification	Tested and monitored by TÜV Süd

WHEEL

Body material	Polypropylene
Tread material	Thermoplastic rubber
Bearing	Precision ball bearing
Threadguards	Integrated threadguard
Diameter	150 mm
Tread width	32 mm
Hardness of tread (A)	87 Shore A

HOUSING

Material fork	Steel sheet, medium
Fork shape	Closed
Swivel bearing	Two ball races
Offset	45 mm
Swivel radius	120 mm
Swivel interference	240 mm

FITTING

Fitting type	Solid stem, round
Bolt diameter	32 mm
Bolt length	45 mm



IF
Design
Award



Red Dot
Design
Award

INTEGRAL

2070PJP150R05-32

EAN 4031582348408



BETTER MOBILITY. BETTER LIFE.

TECHNICAL DRAWINGS

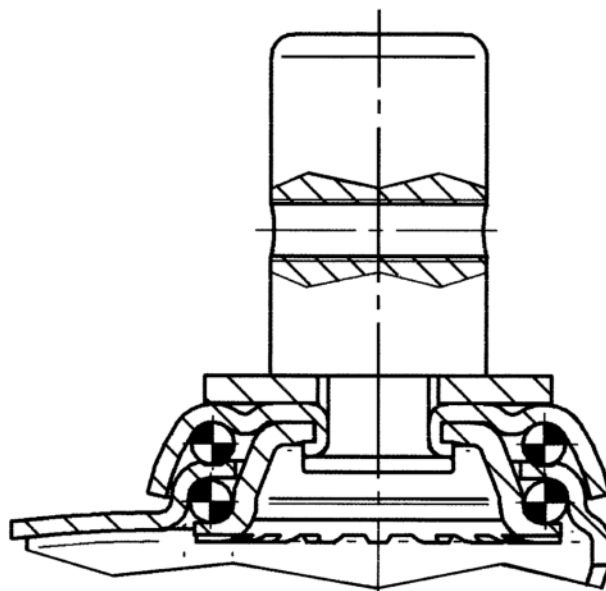

IF
Design
Award



Red Dot
Design
Award