

LINEA

594CUAP125P30-11/180/1D 9002/K3000

EAN 4031582378290



BETTER MOBILITY. BETTER LIFE.



Afbeelding kan afwijken van het oorspronkelijke product

PRESTATIES

Rolprestaties	● ● ● ● ●
Bewegingsgeluid	● ● ● ○ ○
Slijtage	● ● ● ● ○
Corrosiebestendigheid	● ● ● ● ○

KERNKENMERKEN

Productnaam	Linea
Type	Wielen met gecombineerd slot
Standaard	EN12530 - Hulpmiddelen zwenkwielen
Draagvermogen bij 3 km/h	130 kg
Elektrisch geleidend	Nee
Roestvrij	Nee
Statisch draagvermogen	260 kg
Temperatuurbereik (minimaal)	-20 °C
Temperatuurbereik (maximaal)	60 °C
Totale hoogte	143 mm
Totale breedte	82 mm
Totaal gewicht	1,01 kg
Certificering	Getest en gecontroleerd door TÜV Süd

BEHUIZING

Materiaal van de behuizing	Polyamide
Vork Vorm	Behuizing met twee Wiel
Zwenklager	Precisie kogellagers
Kleur	Grijs wit (RAL9002)
Offset	40 mm
Zwenk radius	129 mm
Draaicirkel	258 mm
Diameter koepel	52 mm

WIEL

Materiaal wielkern	Polyamide
Materiaal loopvlak	Polyurethaan, Gespoten
Lagering	Precisie kogellagers
Loopvlak	Leigrijs (RAL7015)
Wielkleur	Leigrijs (RAL7015)
Afdekkapjes	Met draadbeschermer
Diameter	125 mm
Breedte Loopvlak	20 mm
Diameter Asgat	0 mm
Naaflengte	0 mm
Breedte wielkern	20 mm
Hardheid van het Loopvlak (A)	92 Shore A

FITTING

Type bevestiging	Boutgat
Boutgat diameter	11 mm



Deutscher
Ontwerper
Club



Interzum
Award



product
design
award

IF Design
Award

LINEA

594CUAP125P30-11/180/1D 9002/K3000

EAN 4031582378290

Bestelnummer 00771208
Product Drawings



BETTER MOBILITY. BETTER LIFE.

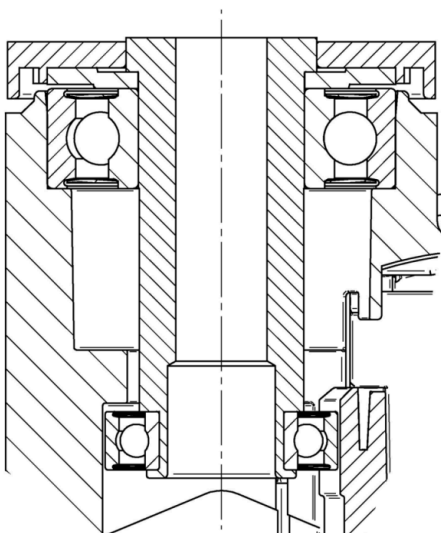
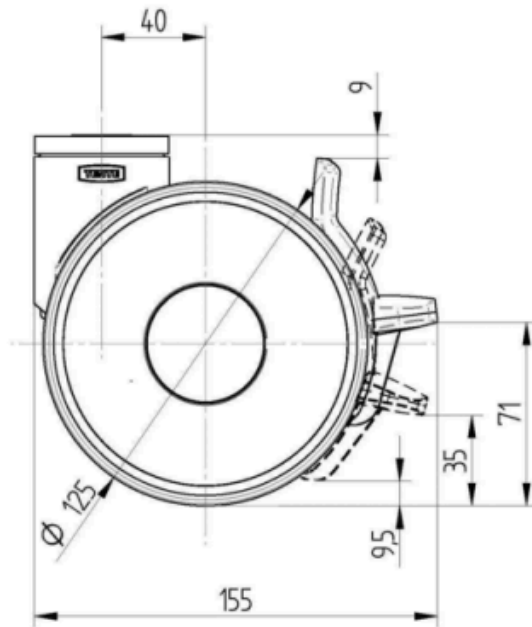
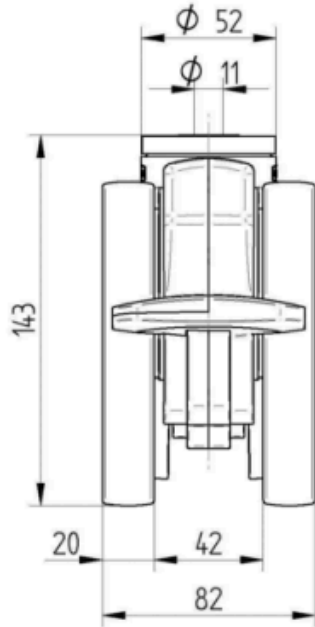

Deutscher
Ontwerper
Club



Interzum
Award



product
design
award

IF Design
Award