

PRODUCT INFORMATION

# NOVATECH

FTP 150x50-Ø20 HL60

EAN 4031582329452



BETTER MOBILITY. BETTER LIFE.



Image may differ from the original product

### WHEEL

Body material	Casting
Tread material	Polyurethane, casted
Bearing	Precision ball bearing
Wheel color	Honey yellow (RAL1005)
Threadguards	With threadguard
Diameter	5.91 in
Tread width	1.97 in
Axle hole diameter	0.79 in
Hub length	2.36 in
Body width	1.97 in
Hardness of tread (A)	92 Shore A
Hardness of tread (D)	42 Shore D

### PERFORMANCE

Roll Performance	●●●●○
Movement noise	●●●○○
Attrition	●●●●○
Corrosion resistance	●●●○○

### CORE ATTRIBUTES

Product name	Novatech
Type	Wheel
Standard	EN12533 - Heavy Duty Castors
Load capacity at 2.5 mph	1851.88 lb
Load capacity at 3.7 mph	1543.23 lb
Electric conductive	no
Stainless	no
Load capacity Static	3086.47 lb
Temperature range (Minimum)	14 °F
Temperature range (Maximum)	140 °F
Overall weight	5.39 lb

# NOVATECH

FTP 150x50-Ø20 HL60

EAN 4031582329452

Order number 00800993  
Product Drawings



BETTER MOBILITY. BETTER LIFE.

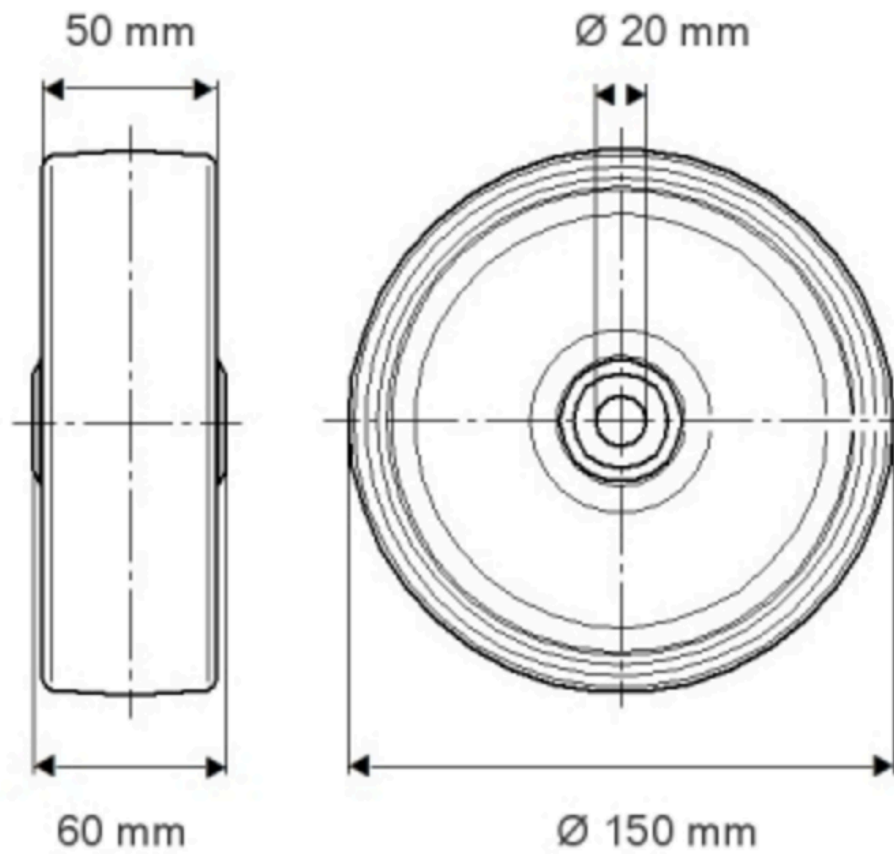

PRODUCT INFORMATION

# NOVATECH

FTP 150x50-020 H160

EAN 4031582329452

Order number 00800993

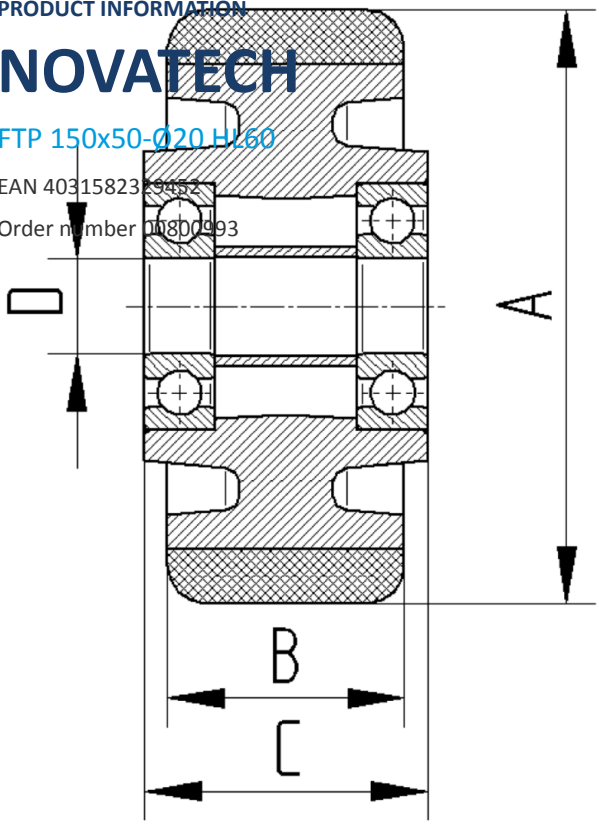

BETTER MOBILITY. BETTER LIFE.