

AVIANA

5976PJE075P54 LIGHT STANDARD 7001

EAN 4031582370966
Order number 00036982



BETTER MOBILITY. BETTER LIFE.



Image may differ from the original product

PERFORMANCE

Roll performance	●●●○○
Movement noise	●●●●●
Attrition	●●●○○
Corrosion resistance	●●●●●

CORE ATTRIBUTES

Product name	Aviana
Type	Swivel castor with central, total lock
Standard	EN12530 - Devices Castors
Load capacity at 3 km/h	100 kg
Load capacity Static	200 kg
Temperature range (Minimum)	-10 °C
Temperature range (Maximum)	40 °C
Overall height	102 mm
Overall width	69 mm
Overall weight	0.341 kg

WHEEL

Body material	Polypropylene
Tread material	Thermoplastic rubber
Bearing	Cone ball bearing, stainless
Wheel color	Silver grey (RAL7001)
Diameter	75 mm
Tread width	25 mm
Body width	25 mm
Hardness of tread (A)	87 Shore A

HOUSING

Material fork	Polyamide
Fork shape	Twin wheel housing
Swivel bearing	Two ball races
Colour	Silver grey (RAL7001)
Offset	28 mm
Swivel radius	68.5 mm
Swivel interference	137 mm
Dome diameter	54 mm

FITTING

Fitting type	Rectangular plate with brake elements
Plate length	70 mm
Plate width	55 mm
Plate hole length (Minimum)	51 mm
Plate hole length (Maximum)	41 mm
Plate hole width (Minimum)	51 mm
Plate hole width (Maximum)	57 mm
Plate hole diameter	5.5 mm



Red Dot
Design
Award



German
Design
Award

AVIANA

5976PJE075P54 LIGHT STANDARD 7001

EAN 4031582370966
Order number 00036982



BETTER MOBILITY. BETTER LIFE.

TECHNICAL DRAWINGS

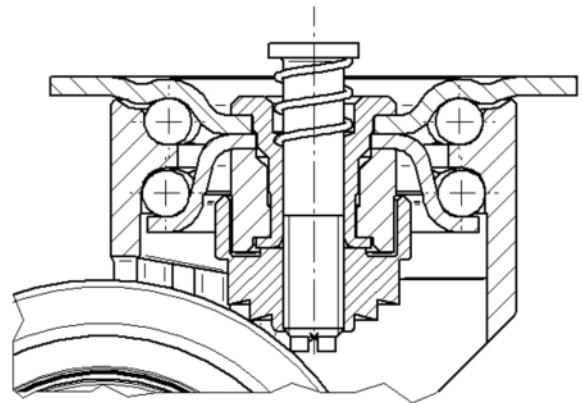
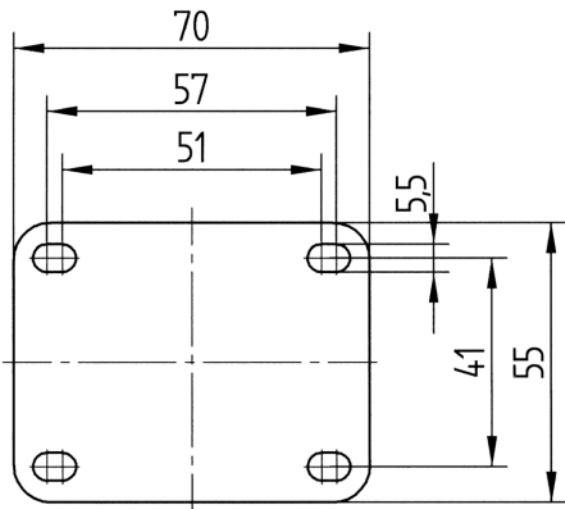
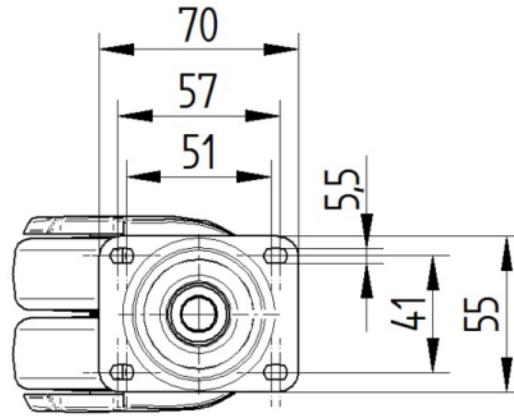
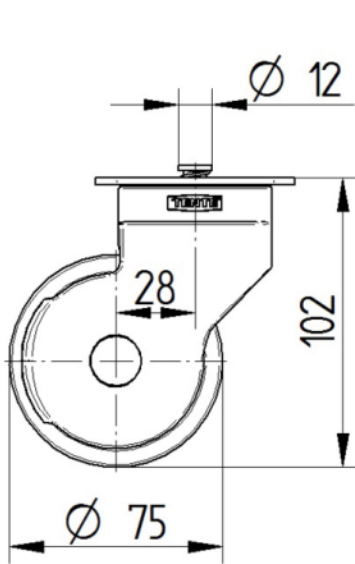

Red Dot
Design
Award



German
Design
Award