

# LINEA

5941UAC125P50 RAL9002

EAN 4031582353235



BETTER MOBILITY. BETTER LIFE.



Image may differ from the original product

## PERFORMANCE

Roll performance	● ● ● ● ●
Movement noise	● ● ● ○ ○
Attrition	● ● ● ● ○
Corrosion resistance	● ● ● ● ○

## CORE ATTRIBUTES

Product name	Linea
Type	Swivel castor with directional lock
Standard	EN12530 - Devices Castors
Load capacity at 3 km/h	130 kg
Stainless	✓
Load capacity Static	260 kg
Temperature range (Minimum)	-10 °C
Temperature range (Maximum)	40 °C
Overall height	148 mm
Overall width	82 mm

## WHEEL

Body material	Polyamide
Tread material	Polyurethane, injected
Bearing	Precision ball bearing, stainless
Threadguards	With threadguard
Diameter	125 mm
Tread width	20 mm
Hardness of tread (A)	92 Shore A

## HOUSING

Material fork	Polyamide
Fork shape	Twin wheel housing
Swivel bearing	Precision ball bearing
Colour	Grey white (RAL9002)
Offset	40 mm
Swivel radius	129 mm
Swivel interference	258 mm
Dome diameter	52 mm

## FITTING

Fitting type	Rectangular plate
Plate length	77 mm
Plate width	67 mm
Plate hole length (Minimum)	56 mm
Plate hole length (Maximum)	61.5 mm
Plate hole width (Minimum)	46.5 mm
Plate hole width (Maximum)	51.5 mm
Plate hole diameter	8.5 mm



Deutscher Designer Club



Interzum Award



IF Design Award

PRODUCT INFORMATION

# LINEA

5941UAC125P50 RAL9002

EAN 4031582353235

TECHNICAL DRAWINGS

---

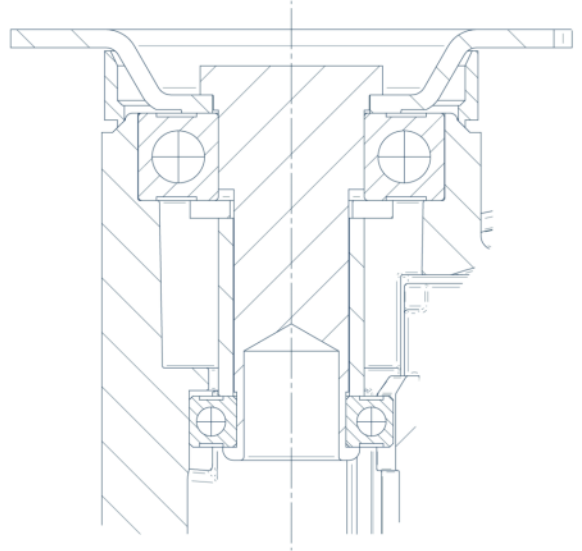

Deutscher  
Designer  
Club



Interzum  
Award



IF  
Design  
Award