

ICS

5328UAP100P52

EAN 4031582384680



BETTER MOBILITY. BETTER LIFE.



Image may differ from the original product

PERFORMANCE

Roll performance	●●●○○
Movement noise	●●●●●
Attrition	●●●●○
Corrosion resistance	●●●●●

CORE ATTRIBUTES

Product name	ICS
Type	Fixed castor
Standard	EN12530 - Devices Castors
Load capacity at 3 km/h	100 kg
Load capacity Static	200 kg
Temperature range (Minimum)	-10 °C
Temperature range (Maximum)	40 °C
Overall height	141 mm

WHEEL

Body material	Polyamide
Tread material	Polyurethane, injected
Bearing	Precision ball bearing
Threadguards	Integrated threadguard
Diameter	100 mm
Tread width	32 mm
Hardness of tread (A)	92 Shore A
Hardness of tread (D)	42 Shore D

HOUSING

Material fork	Polyamide
Fork shape	Slim

FITTING

Fitting type	Rectangular plate, US-bolt hole spacing
Plate length	95 mm
Plate width	70 mm
Plate hole length (Minimum)	44.45 mm
Plate hole length (Maximum)	52 mm
Plate hole width (Minimum)	72 mm
Plate hole width (Maximum)	76 mm
Plate hole diameter	11 mm



IF
Design
Award

ICS

5328UAP100P52

EAN 4031582384680



BETTER MOBILITY. BETTER LIFE.

TECHNICAL DRAWINGS

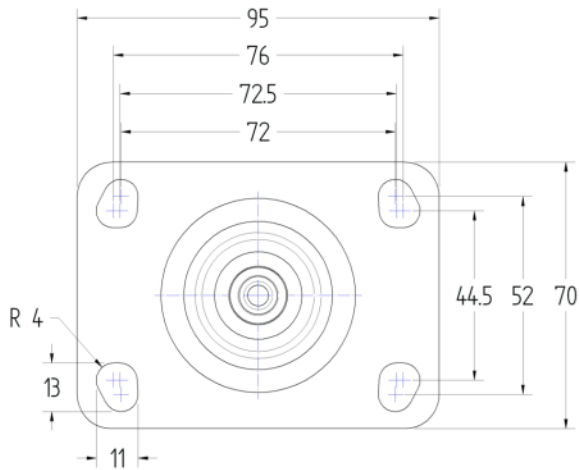

IF
Design
Award