

LINEA

5941UAC100P30-13 RAL9002

EAN 4031582352603



BETTER MOBILITY. BETTER LIFE.



Image may differ from the original product

PERFORMANCE

Roll performance	● ● ● ● ●
Movement noise	● ● ● ○ ○
Attrition	● ● ● ● ○
Corrosion resistance	● ● ● ● ○

CORE ATTRIBUTES

Product name	Linea
Type	Swivel castor with directional lock
Standard	EN12530 - Devices Castors
Load capacity at 3 km/h	120 kg
Stainless	✓
Load capacity Static	240 kg
Temperature range (Minimum)	-10 °C
Temperature range (Maximum)	40 °C
Overall height	118 mm
Overall width	82 mm
Overall weight	0.723 kg

WHEEL

Body material	Polyamide
Tread material	Polyurethane, injected
Bearing	Precision ball bearing, stainless
Threadguards	With threadguard
Diameter	100 mm
Tread width	20 mm
Hardness of tread (A)	92 Shore A

HOUSING

Material fork	Polyamide
Fork shape	Twin wheel housing
Swivel bearing	Precision ball bearing
Colour	Grey white (RAL9002)
Offset	32 mm
Swivel radius	108 mm
Swivel interference	216 mm
Dome diameter	52 mm

FITTING

Fitting type	Bolt hole
Bolt hole diameter	13 mm



Deutscher Designer Club



Interzum Award



IF Design Award

LINEA

5941UAC100P30-13 RAL9002

EAN 4031582352603



BETTER MOBILITY. BETTER LIFE.

TECHNICAL DRAWINGS

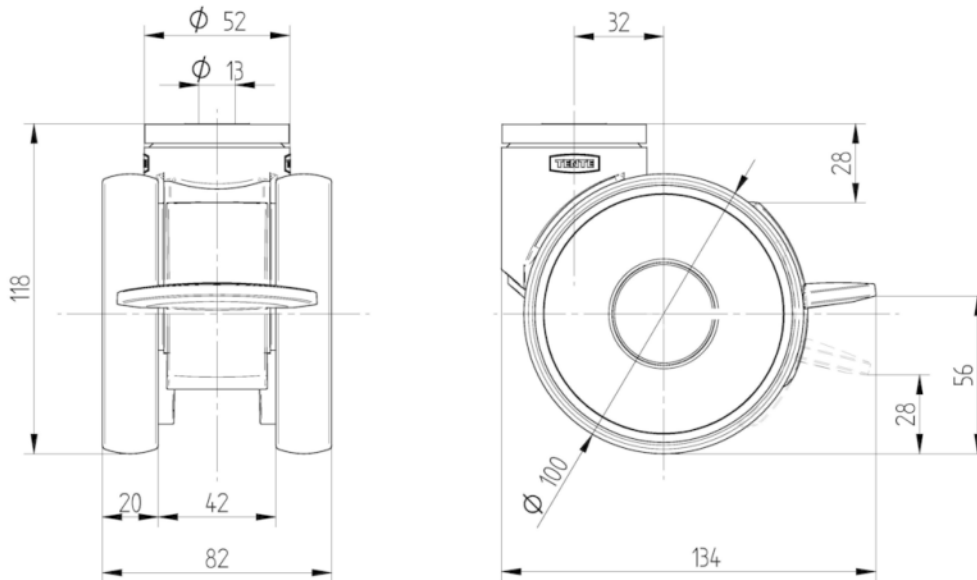

Deutscher
Designer
Club



Interzum
Award



IF
Design
Award